

## **SECTION II—CIRCULAR 43-E**

### **CIRCULAR 43-E**

**RULES GOVERNING THE LOADING, BLOCKING AND BRACING  
OF FREIGHT IN CLOSED TRAILERS AND CONTAINERS  
FOR TOFC/COFC SERVICE**

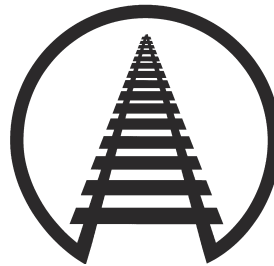

**Issued by:  
ASSOCIATION OF AMERICAN RAILROADS**

**(Printed in U.S.A.)  
© 2011**

## A—INTRODUCTION

These rules, which supersede Circular 43-D as issued in 2001, apply both to trailers and containers regardless of shipping plan used. Reference to, or illustrations of, trailers in this publication includes both containers and trailers.

These rules are designed for the benefit of all parties concerned. By adhering to the rules, both lading and equipment will be protected in the absence of unusual circumstances.

It must be understood that trailers or containers may move in a backwards or reverse direction for all or a portion of their journey. During its journey, normal transportation forces will shift an unsecured load or cause lading to exert excessive pressure against the nose, rear doors, or sidewalls. It is therefore imperative that trailers or containers moving in rail service be loaded by the shipper in strict compliance with the General Rules as contained in this publication. Shipper is defined in these rules as that party or his agent who is responsible for the physical loading and securement of the lading in the trailer or container.

If loading rules, illustrations, or principles contained in this publication appear not to cover a specific shipment being tendered for TOFC/COFC movement, contact the origin carrier's *loss and damage prevention representative* for assistance and/or instructions.

Loading rules contained herein apply to shipments transported in the USA, Canada, and Mexico.

General information and approved loading methods for TOFC/COFC shipments are published in [Sections III and IV](#) of this *Intermodal Loading Guide*.

## B—GENERAL RULES

The following rules have been formulated for the purpose of providing *safe* methods of loading closed trailers and containers and *must* be observed. The primary purpose of these rules is safe transit of trailers and containers from origin to destination. Reference to, or illustration of, trailers in this publication includes both trailers and containers.

### 1. Inspection and Selection of Equipment

A. It is the equipment supplier's responsibility to furnish trailers that are clean and have sound roofs, sides and end walls, smooth floors, and snug-fitting doors. **There must be no obvious damage, distress, weakened parts, or weakened sections.** Any exception is cause for rejection. **The trailer or container must be appropriate for the lading it is to transport.** The shipper also has a responsibility to inspect the trailer or container at origin to see that it is suitable to carry lading safely to destination.

B. It is important that **trailers or containers** be clean and free from nails and other protruding objects.

C. If trailer or container supplied is not suitable for loading and shipper elects to load this trailer or container rather than reject it, it is the shipper's responsibility to properly prepare the trailer or container .

### 2. Planning of Load

A. Plan loading to prevent damage to lading and equipment. Lading that is obviously unsuitable for movement in a trailer or container, as far as safety in handling and protection to lading and equipment are concerned, is not to be loaded.

### 3. Maximum Weights, Weight Distribution, and Center of Gravity

A. The load weight *must not* exceed the limit as stated on the manufacturer's plate. Combined weight of trailer and lading may not exceed 65,000 lb.\* Combined weight of container and lading may not exceed the weight specified below for the length of container being loaded:

Nominal Length (ft)	Maximum Gross Weight (lb)** (Lading Plus Tare)
53	67,200
48	67,200
45	67,200
40	67,200
28	52,900
20	52,900

\*Maximum weights as defined in current AAR Specification M-931-04 for trailers (effective 2/1/04 and subject to revisions thereto).

\*\*Maximum weights as defined in current AAR Specification M-930-08 for containers (implemented 10/2008), and subject to revisions thereto.

B. Lading weight in trailers or containers must be evenly distributed both crosswise and lengthwise, and combined weight of lading and trailer or container must conform to all federal, state, provincial, and local regulations and transportation service requirements used at origin and to final destination. (See [Illustrations 1, 2, 3, and 4.](#))

C. Combined center of gravity (measured from top of rail) of car, trailer or container, and load is not to exceed 98 in.

### 4. Hazardous Materials/Hazardous Substances

A. Loads containing any quantity of hazardous materials/hazardous substances must conform to the regulations of the agency of authority of the countries within which the shipment will move. Some but not all regulations are as follows:

- Department of Transportation Regulations as published in Bureau of Explosives Tariff 6000 series and supplements thereto
- Transportation of Dangerous Goods Regulations and supplements thereto, as administered by the Transport of Dangerous Goods Directorate (Transport Canada)
- Mexican shipments are governed by Bureau of Explosives Tariff 6000 series and supplements thereto.

B. Carrier is to be specifically informed on shipping orders as to the presence, type, characteristics, and volume of all hazardous materials/hazardous substances.

### 5. Loading and Securement

A. Secure lading to prevent both lengthwise and crosswise movement. If the lading is rigid in nature and/or very dense, such as boxes of nuts and bolts, machinery, metal beams, brick, lumber, cut paper, etc., or if the shape of the lading is such that the area of door contact is minimal, such as with cylindrical objects like drums or rolled paper, blocking and bracing is necessary. Vehicle doors are neither designed nor intended to restrain commodities with these characteristics. Such products must be loaded and secured in conformance with the rules and illustrations in this publication and in other applicable AAR commodity loading publications.

*Trailer/container doors may not be used to secure loads containing hazardous materials.*

The doors of the vehicle, meeting AAR trailer specification M-931 and AAR container specification M-930, can be relied on to secure *non-hazardous materials* lading only under the following conditions:

1. The load consists of multi-unit lading such as boxes of food-stuff, tissue, or soft paper products, furniture, appliances, etc., not exceeding 40,000 lb, covering a minimum of 60% of the door area and evenly distributed throughout the vehicle.
2. Lading must be loaded tightly lengthwise and crosswise and flush to the rear doors of the vehicle allowing no room for movement. If any void exists, fill void space with recommended dunnage.
3. The doors must fit squarely, the hinges must be tight, and locking bars must be in good condition and function properly.

See [Illustration 46](#) in [Section III](#).

B. Fill voids and apply blocking and bracing to maintain proper lengthwise and crosswise weight distribution during transit and to prevent lading from damaging doors, nose, and walls or from falling out when doors are opened.

C. Secure machinery or other equipment that has a high center of gravity to prevent tipping. (See [Illustration](#) .)

D. Use lumber that is of sound material and free of defects that impair its strength or interferes with proper nailing. (See [Illustration 32](#) in [Section III](#).)

E. Use adequate size and number of nails in the construction and the securement of blocking and bracing within the trailer or container. (See [Table A](#) on [page 3-22](#) and [Table B](#) on [page 3-23](#) of [Section III](#).)

F. Do not nail into the walls of trailers or containers. Toe-nailing is not permitted, except as specifically exempted by applicable AAR commodity loading publications.

G. Strapping used for load securement must be of sufficient strength and amount and be properly applied so as to secure the load from crosswise or lengthwise movement.

H. The combined joint strength of steel straps used must be equal to the weight of the lading being secured, except as provided in approved loading methods in [Section IV](#) of this *Intermodal Loading Guide*. (See [Table E](#) on [page 3-27](#) of [Section III](#).)

I. High-tension band sizes 1¼ in. and 2 in. used for load securements are to be marked to indicate manufacturer's or supplier's name and the letters "AAR."

Markings shall consist of the letters "AAR," the manufacturer's or distributor's name or abbreviated name, or registered trademark, or symbol, or AAR code consisting of two digits. Markings shall be in characters not less than ⅛ in. high for steel die imprint and not less than ¼ in. high for paint, ink surface printing, or embossing, spaced at not more than 5 ft intervals.

Markings applied to high tension bands manufactured to metric dimensions must be followed by the letter "M" of the same size as the original marking.

The following methods of marking for purpose of identification have been assigned to manufacturers and suppliers whose products have been tested by the AAR and found to meet the requirements of this Rule.

<b>Name</b>	<b>Method of Marking</b>	<b>Markings</b>
ITW/Acme Packaging	Steel Embossed	AAR 11
ITW/Signode	Steel Embossed	AAR 11
Samuel Strapping Systems	Steel Die Imprint, Ink Print	AAR 22, 33, 47
Gerrard-Ovalstrapping	Ink Print	AAR 52
Garibaldi (Chili)	Steel Die Imprint, Ink Print, Paint Embossed	AAR 20
Hankum Co., Ltd.	Ink Print	AAR 26
Maillis Strapping Systems-USA, Inc.	Ink Print	AAR 57
DuBose Strapping	Ink Print	AAR 58

**IMPORTANT—High tension bands must be applied to packages and/or loads with markings facing outward.**

J. Coiled steel and other dense products must be stowed to conform to [Illustration 3](#). A minimum of three runners each 2.7 ft long based on 48 in. on-center spacing are required for each skid or pallet for steel coils and similar products of concentrated weight weighing up to 3,500 lb. The following chart may be used as a guideline when shipping dense products greater than 3,500 lb.

<b>DOMESTIC TRAILERS/CONTAINERS</b>					
<b>Guide to Minimum Required Length of Longitudinal Runners</b>					
<b>Payload Weight</b>	<b>Spacing of Longitudinal Runners (ft)</b>				
	<b>4.0</b>	<b>5.0</b>	<b>6.0</b>	<b>7.0</b>	<b>8.0</b>
<b>4,000</b>	3.3	2.6	2.2	1.9	1.6
<b>5,000</b>	4.1	3.3	2.7	2.3	2.0
<b>6,000</b>	4.9	3.9	3.3	2.8	2.5
<b>7,000</b>	5.7	4.6	3.8	3.3	2.9
<b>8,000</b>	6.5	5.2	4.4	3.7	3.3
<b>9,000</b>	7.4	5.9	4.9	4.2	3.7
<b>10,000</b>	8.2	6.5	5.4	4.7	4.1
<b>11,000</b>	9.0	7.2	6.0	5.1	4.5
<b>12,000</b>	9.8	7.8	6.5	5.6	4.9
<b>13,000</b>	10.6	8.5	7.1	6.1	5.3
<b>14,000</b>	11.4	9.2	7.6	6.5	5.7
<b>15,000</b>	12.3	9.8	8.2	7.0	6.1
<b>16,000</b>	13.1	10.5	8.7	7.5	6.5
<b>17,000</b>	13.9	11.1	9.3	7.9	6.9
<b>18,000</b>	14.7	11.8	9.8	8.4	7.4
<b>19,000</b>	15.5	12.4	10.3	8.9	7.8
<b>20,000</b>	16.3	13.1	10.9	9.3	8.2
<b>21,000</b>	17.2	13.7	11.4	9.8	8.6
<b>22,000</b>	18.0	14.4	12.0	10.3	9.0
<b>23,000</b>	18.8	15.0	12.5	10.7	9.4
<b>24,000</b>	19.6	15.7	13.1	11.2	9.8
<b>25,000</b>	20.4	16.3	13.6	11.7	10.2

Individual carrier approval must be gained when shipping products of concentrated weight greater than 3,500 lb.

## 6. Special Equipment

Some trailers and containers are equipped with special interior fixtures. Properly fasten and lock such equipment in place. Properly secure all special equipment in trailers and containers when empty. The use of any type of material handling equipment to unlock and raise or lower and lock special equipment is prohibited.

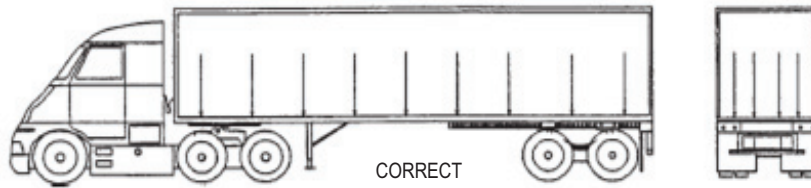

Trailers/containers are designed for uniform load distribution as shown. Distribute the lading equally between the rear tires and the king pin that transfers its load to the truck tractor.

**Illustration No. 1**

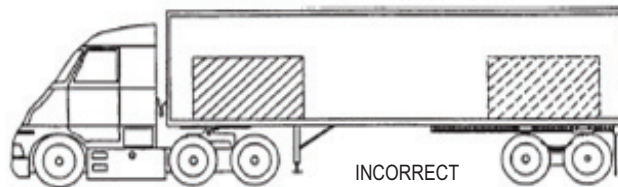

Units loaded in either position indicated are incorrect because weight is not equally distributed to tires and king pin.

**Illustration No. 2**

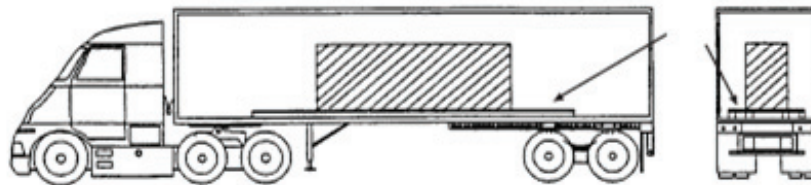

### HIGHLY CONCENTRATED LOADS

Not more than 25,000 lb uniformly distributed in any 10 linear ft can be loaded on trailers meeting the specifications of *AAR Manual of Standards and Recommended Practices*, Specification M-931 or on containers meeting the specifications of *MSRP Specification M-930*. Item A is a skid of adequate length, width, and construction to properly distribute weight. Trailers in intermodal service not meeting the M-931 specifications or containers in intermodal service not meeting the M-930 specifications may be of lower floor strength. Considerations of such must be a part of any load planning, particularly that of highly concentrated loads, e.g., steel coils.

**Illustration No. 3**

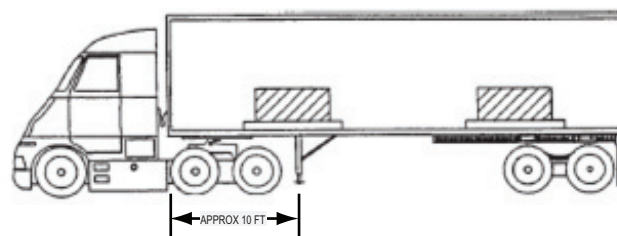

TOFC trailers and containers on chassis are often left unsupported by truck tractors and are lifted by cranes. In positioning two concentrated weight units as illustrated, position the forward unit for equal weight distribution on the landing gear (approximately 10 ft from nose).

**Illustration No. 4**

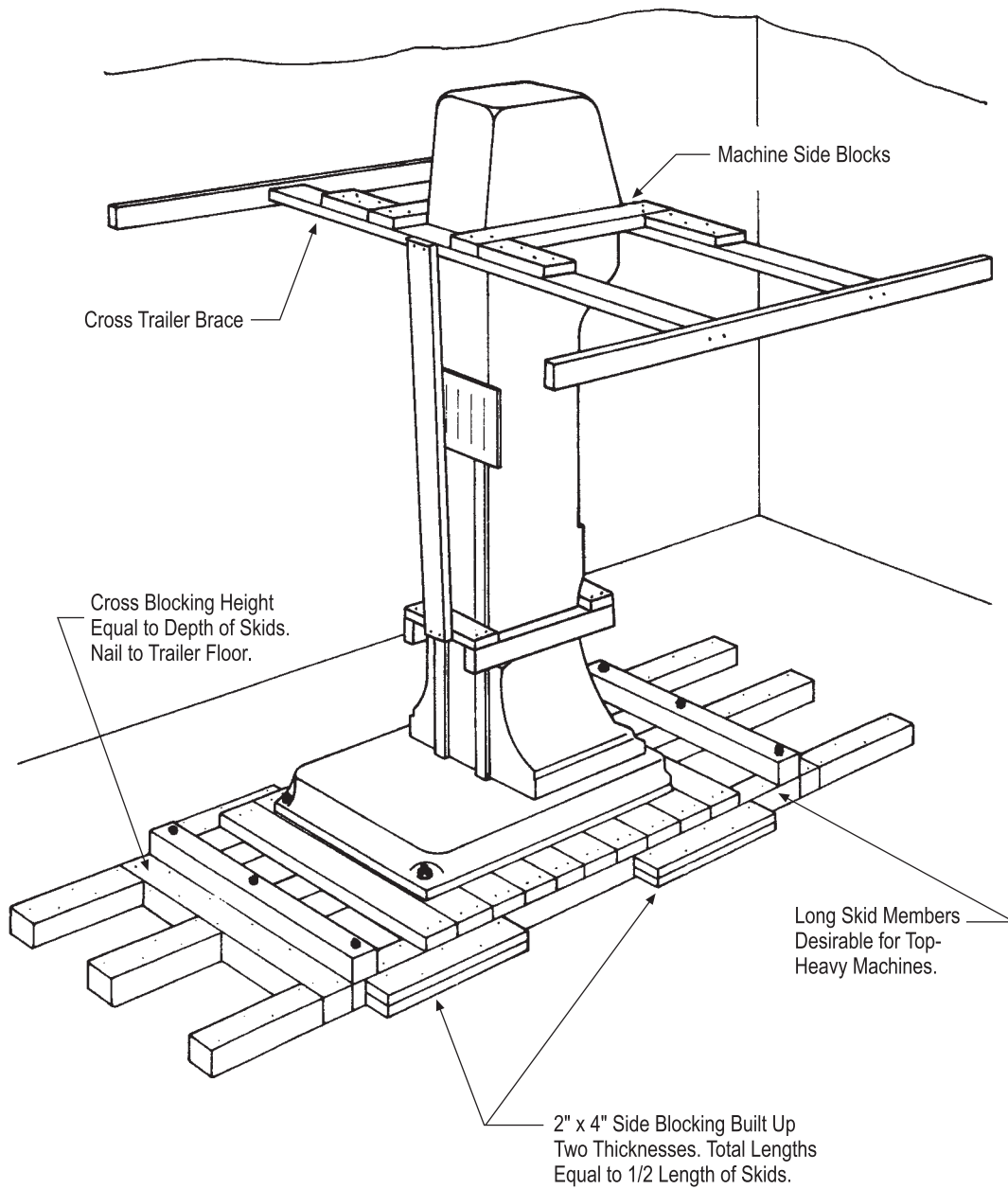

**Illustration No. 5**  
Top-Heavy Machinery—Not Leg Type